ABSTRACT

This paper deals with a microcontroller based solar panel tracking system. Solar energy is rapidly gaining notoriety as an important means of expanding renewable energy resources. My project will include the design and construction of a microcontroller-based solar panel tracking system. Solar tracking enable more energy to be generated because the solar panel is always able to maintain a perpendicular to the sun's rays. Development of solar panel tracking system has been ongoing for several year now. As the sun moves across the sky during the day, it is advantageous to have the solar panel track the sun location, such that the panels are always perpendicular to the solar energy radiated by the sun.

KEYWORDS: Microcontroller AT89C51, Solar Panel, Stepper Motor, Motor Driver, Battery, LDR.

INTRODUCTION

A solar tracker is a device for orienting a Photovoltaic array solar photovoltaic panel or concentrating solar reflector or lens toward the sun. The sun's position in the sky varies both with the seasons (elevation) and time of day as the sun moves across the sky. Solar powered equipment works best when pointed at or near the sun, so a solar tracker can increase the effectiveness of such equipment over any fixed position, at the cost of additional system complexity. There are many types of solar trackers, of varying costs, sophistication, and performance. One well-known type of solar tracker is the heliostat, a movable mirror that reflects the moving sun to a fixed location, but many other approaches are used as well.

Non-concentrating applications require less accuracy, and many work without any tracking at all. However, tracking can substantially improve both the amount of total power produced by a system and that produced during critical system demand periods (typically late afternoon in hot climates). The use of trackers in non-concentrating applications is usually an engineering decision based on economics. Compared to photo voltaic, trackers can be inexpensive. This makes them especially effective for photovoltaic systems using high-efficiency (and thus expensive) panels.

Extracting usable electricity from the sun was made possible by the discovery of the photoelectric mechanism and subsequent development of the solar cell – a semi conductive material that converts visible light into a direct current. By using solar arrays, a series of solar cells electrically connected, a DC voltage is generated which can be physically used on a load.

BLOCK DIAGRAM

Figure:

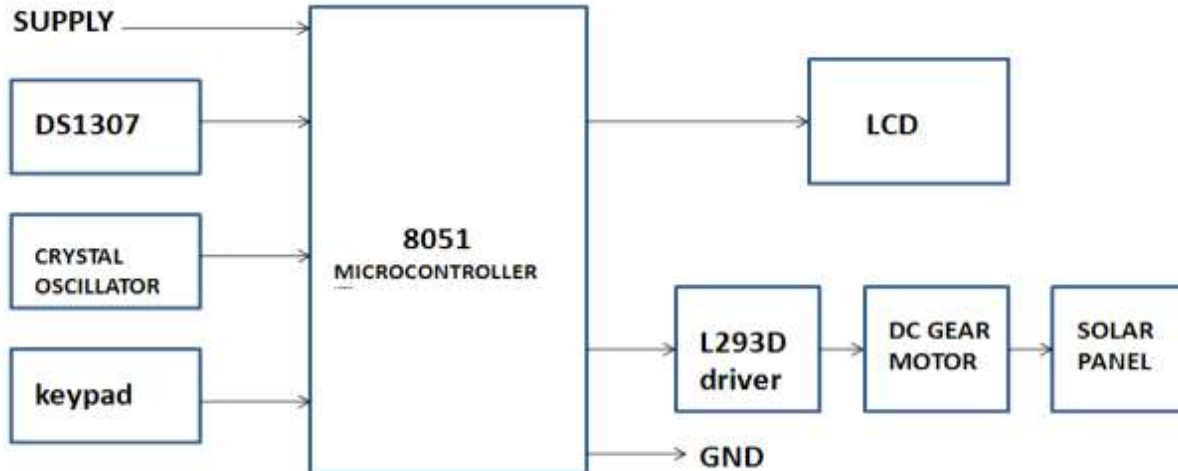

Figure no.1: Block diagram of solar tracking system.

WORKING PRINCIPLE

The system contains two modules, one is tracking and the other is controlling module. Tracking module which will take angular rotation with the help of DC gear motor in synchronous with the starting position of the sun. As sun rises from East, it will also take the angle according to the angle of raising sun. So it will continuously track the sun till the sun sets in the West.

Initially when the supply from the power kit was drawn and given to all the components of the control circuit and keyboard. When the power supply is switched ON the panel comes to the original position and by the keypad switches the clock time in the LCD screen can be set by the keypad switches. K1, K2 and K3 are the switches of keypad. K1 represents Increment switch, K2 represents Decrement switch and K3 represents Enable switch. Initially the panel stands at reference position 8:00AM and according to the setting time the panel rotates with the help of brushless DC Gear Motor.

Module is designed with efficient Microcontroller from ATMEL 89C51 which helps to drive the tracking module at different instants. The keypad switches was connected to the microcontroller through latch to the port2(Pins 2.6, 2.7,2.8) and microcontroller was connected to the LCD screen through the pins(P1.4 to P1.7) and the LCD displays the preset time.

DS1307 is the RTC(Real Time Clock) used to produce clock pulses through microcontroller which connects the LCD display, displays the time.

L293D driver was connected to the DC Motor, microcontroller and 9V battery. The pulses that was produced by the microcontroller helps to connect the DC supply to the DC brushless motor.

The DC brushless motor was mounted on a separate stand and connected to a shaft which rotates the solar panel given from the microcontroller based upon this gear motor operates.

COMPONENT USED

The major components of this system are as follows.

1. Microcontroller 8051 (Atmel 89C51 used)
2. Comparator LM324
3. LDRs
4. Motor driver L293D
5. Stepper motor

Other auxiliary components are:

1. Resistor (10K Ω , 1K Ω .)
2. Capacitor (10 μ F, 33pF)
3. Crystal oscillator (11.0592 MHz)
4. 5V and 6V power supply

Except these components the connecting wire, circuit board other devices are used. A USB based Superpro 280U universal programmer is used to burn the chip (to load the program in the chip. A PC with two software, compiler (ASM) notepad and 8052 simulator is needed.

CIRCUIT DIAGRAM & DISCRPTION

1. The Microcontroller part: In the figure the interfacing circuitry of the Unipolar Stepper Motor with microcontroller AT89C51 is shown. The AT89C51 provides a set of standard features: 4K bytes of flash, 128 bytes of RAM, 32 I/O lines, two 16-bit timer/counters, five vector two-level interrupt architecture. Here we have used L293D as the motor driver. Port 1 is getting the input from the output of the comparator in particular bit pattern. Using program it is compared the bit pattern and send signal to the motor driver to drive the stepper motor in specified direction.

2. Motor driver L293D with stepper motor part: The L293D is a quadruple high-current half-H driver designed to provide bidirectional drive currents of up to 600-mA at voltages from 4.5 V to 36 V. It is designed to drive inductive loads such as relays, solenoids, dc and bipolar stepping motors, as well as other high-current/high-voltage loads in positive-supply applications. There are three ways to drive unipolar stepper motors (one phase on full step, two phases on full step, or half step), each one has some advantages and disadvantages. In this project two phase full step mode is used.

Table 1. bit pattern for motor driver L293D

S t e p	1 a	1 b	2 a	2 b
1	1	0	0	1
2	1	1	0	0
3	0	1	1	0
4	0	0	1	1

In two phase mode, successive pairs of adjacent coils are energized in turn, motion is not as smooth as in one phase mode, power consumption is more important but it produces greater torque As in one phase mode, applying the steps in order makes the stepper motor run clockwise and reversing order makes it turn counter-clockwise.

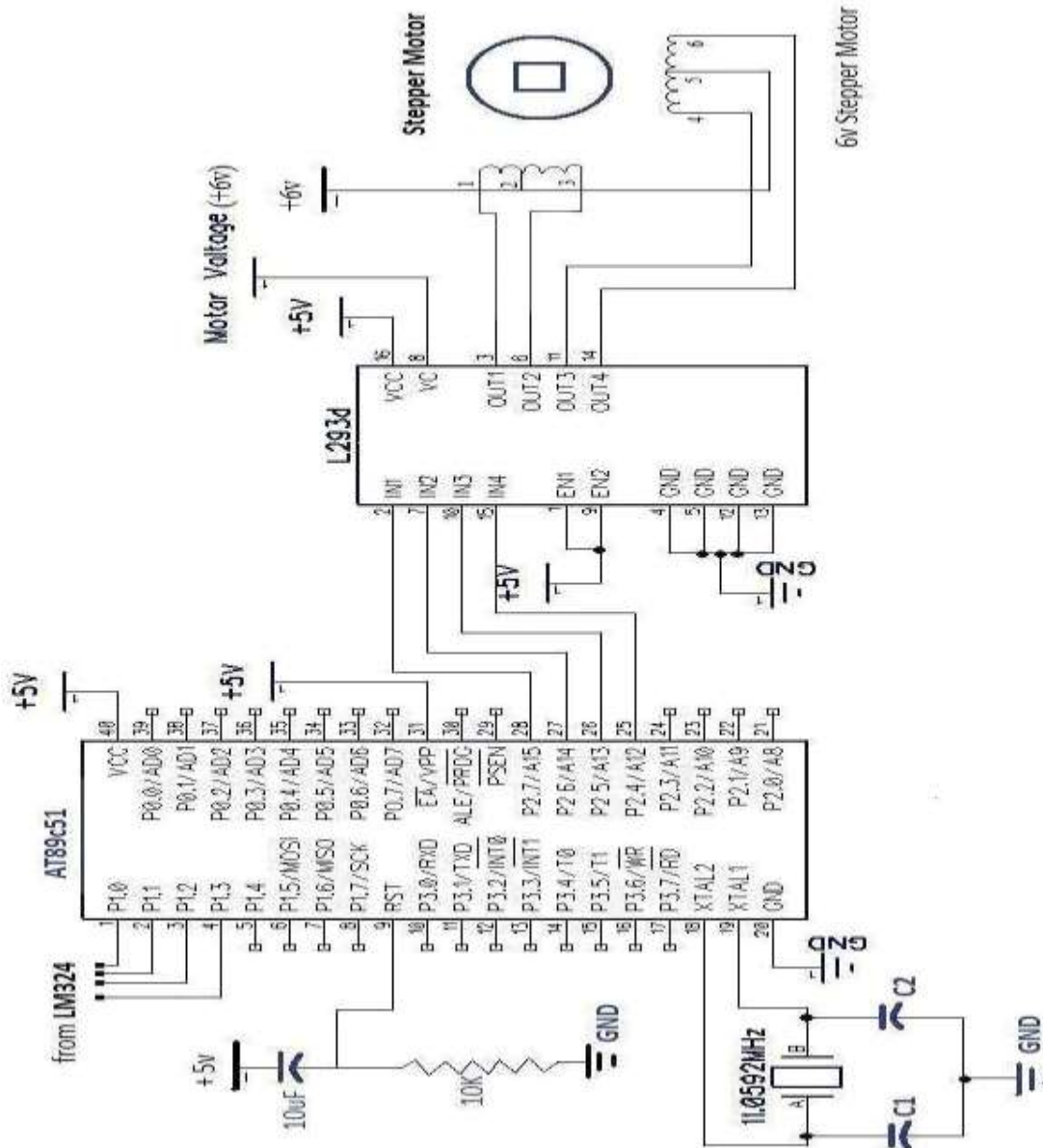

Figure no.2: Circuit Diagram of Solar Tracking System.

Circuit Features:

Brief description of operation: Gives out well regulated +5V output, output current capability of 1A

Circuit complexity: Very simple and easy to build

Circuit performance: Very stable +5V output voltage, reliable operation Availability of components: Easy to get, uses only very common basic components

Applications: Part of electronics devices, small laboratory power supply

Power supply voltage: 230V AC

Power supply current: 1A

3. Step Angle: Step angle of the stepper motor is defined as the angle traversed by the motor in one step [8]. To calculate step angle, simply divide 360 by number of steps a motor takes to complete one revolution.

As we have seen that in half mode, the number of steps taken by the motor to complete one revolution gets doubled, so step angle reduces to half. As in above examples, Stepper Motor rotating in full mode takes 4 steps to complete a revolution, So step angle can be calculated as... Step Angle $\theta = 360^\circ / 4 = 90^\circ$ and in case of half mode step angle gets half so 45° . So this way we can calculate step angle for any stepper motor[8]. In morning when sun rises in the east 1st and 2nd LDR getting maximum intensity of light the motor rotates in a specified angle. Then sometimes latter 2nd and 3rd LDR will get maximum light then stepper motor rotates next specified angle. Similarly next 3rd and 4th LDR will get maximum light. After sun set in the west stepper motor return back means solar panel will be at initial position

4. SOFTWARE PART: The microcontroller chip AT89C51 is directed as the program in its flash memory instructs it. So it is obvious to load the program into the chip. Program is written in ASM notepad and compiled. If any compilation error occurs, then it is debugged. Then the HEX-code is generated. Then the program is simulated in 8052 simulator. This gives an opportunity to see what will be the result of the code. If the code gives desired result then the USB based superpro is used to load the program; or to burn 'the chip. USB based superpro is basically a universal programmer. After downloading the HEX code in the chip is again connected to the main circuit.

CONCLUSION

In this project a solar tracker has been developed to increase the amount of power generated by the solar panel as the sun traverses across the sky. An 8051 microcontroller was used to control the movement of the solar panel. The system is designed to be autonomous; such that energy generated by the solar panel would be used to charge two lead acid batteries. In this project some difficulties regarding the placement or the LDRs is faced, so that at a same time more than two LDR do not get activated. All the readings are taken very carefully during the project to eliminate the errors as many as possible. Solar Energy is one of the most popular renewable sources nowadays. It is being widely used also, and within some more years it will be very popular that it will be used for many purposes, in industries and household as well. So it is most important fact to utilize the maximum energy of the sun so that maximum power can be generated. The thought behind this project is also derived from this fact. In many places experiment is being done on this fact how it is possible to make full use of the day light. In many places application of this project can be seen also. This project has got a bright future scope further. Accuracy of this solar panel can be increased further and number of steps can be increased as well to get more accurate desired output.

REFERENCES

1. [1] B.Suchitha Samuel, J.Mrudula, —Design of Intelligent Solar Tracker Robot for Surveillance,| International Journal of Advanced Research in Electrical, Electronics and Instrumentation Engineering, Vol. 2, Issue 10, October 2013.
2. [2] Bhavesh Pandey1, Anita Agrawal, —Automatic Sun Tracking System Using PSoC,| International Journal of Innovative Research in Science, Engineering and Technology, Vol. 1, Issue 1, November 2012.
3. [3] Sobuj Kumar Ray, Md. Abul Bashar, Maruf Ahmad & Fahad Bin Sayed , —Two Ways of Rotating Freedom Solar Tracker by Using ADC of Microcontroller |, Global Journal of Researches in Engineering General Engineering|, Volume 12 Issue 4 Version 1.0 Year 2012.
4. [4] Mazidi Md.Ali, Mazidi J.G.,—The 8051 Microcontroller and Embedded systems|, Pearson Education, 2nd edition.
5. kais i. Abdul-lateef, —a low cost single-axis sun tracker system using pic microcontroller,| diyala journal of engineering sciences, vol. 05, no. 01, pp.65-78, june 2012.
6. [6] Meghana Sharma, —An Efficient Low Cost Solar Tracker Using Microcontroller,| IOSR Journal of Electrical and Electronics Engineering (IOSR-JEEE), Volume 9, Issue 4 Ver. V (Jul – Aug. 2014), PP 37-40.